

3 Roller Indexer System

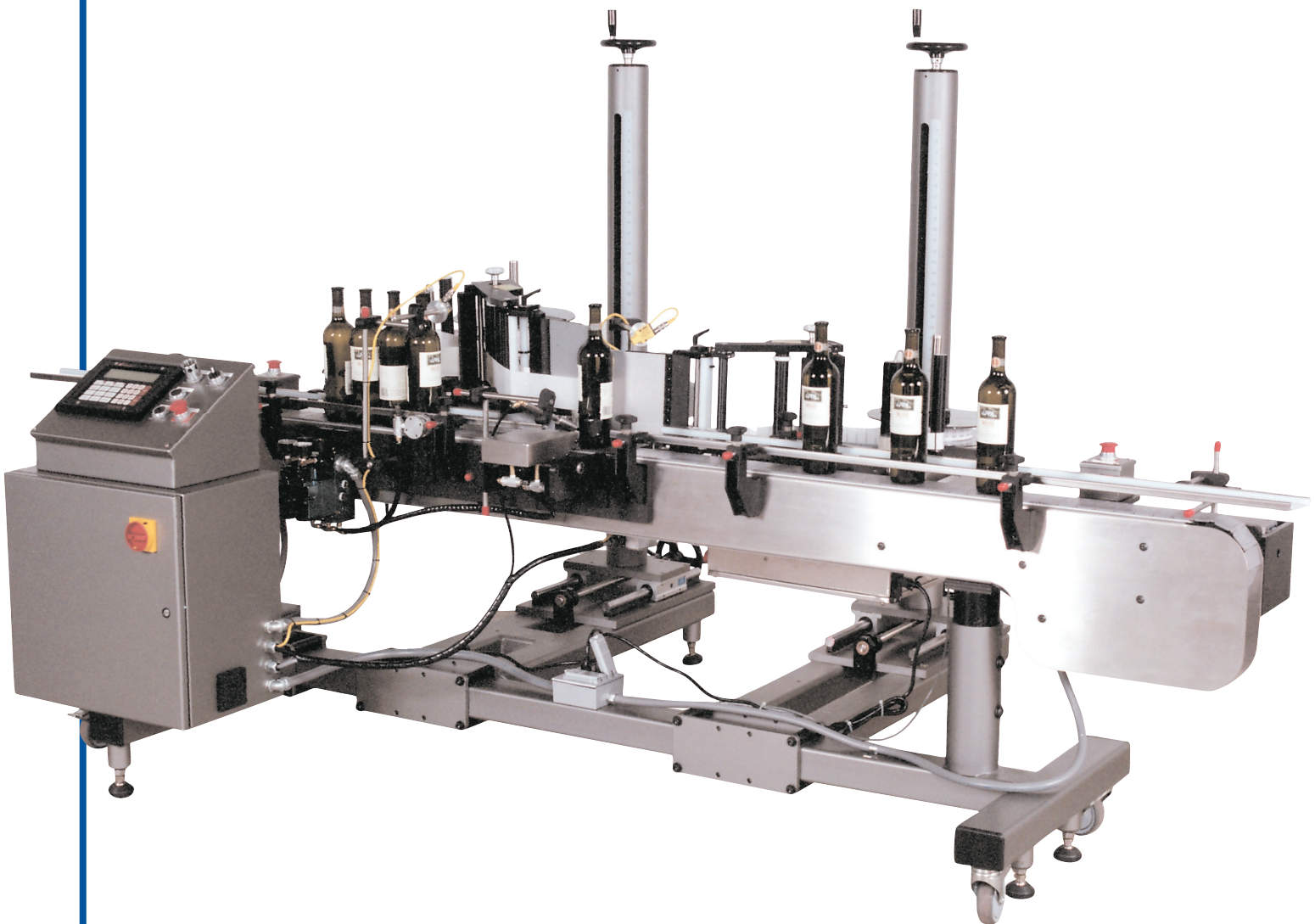

The CTM 3 Roller Indexer System is a high quality system designed around the customer's exact labeling need.



Setting Global Standards
One Customer at a Time

www.ctmlabelingsystems.com

3 Roller Indexer System

Features:

- Heavy Duty Rugged Conveyor Base.
- Stainless Steel Conveyor Sideframes.
- Easily Adjustable Applicator Mount.
- Operator Control Console with 4 line 40 Character operator interface.
- Stepper Driven Indexing Drive Roller.
- Easily Integrated with Existing Lines.

Modes of Operation:

Single labels (front or back) can be applied to various diameter or height wine bottles. Labels can be oriented specifically to physical characteristics, registration marks or existing graphics.

One applicator required.

Front & Back Label Applications

Front & back labeling will require front and back labels to be converted in altering fashion on the same web. As the indexer rotates each bottle, the controller will monitor the bottle's rotation and trigger the applicator to apply the labels 180° opposite each other.

One applicator required.

Front & back labeling can also be accomplished with two applicators. The front labels would be converted on one roll with the back labels being converted on the opposing roll. This would require the indexer to reverse the bottle rotation after the first label has been applied.

Two Applicators required.

Electrical:

120 VAC, 20 amps.

Electronics:

Microprocessor controlled

Pneumatic:

80 PSI @ 3 CFM

Speeds:

Dependent upon applicators used, bottle diameter and label lengths.

Approximate Dimensions:

96" long, 75" wide, 68" tall (single labeler version).

Approximate Shipping Weight:

1179 lbs.

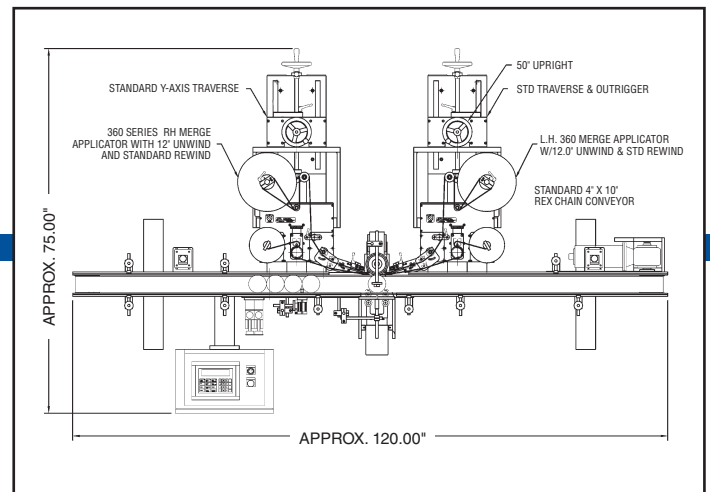
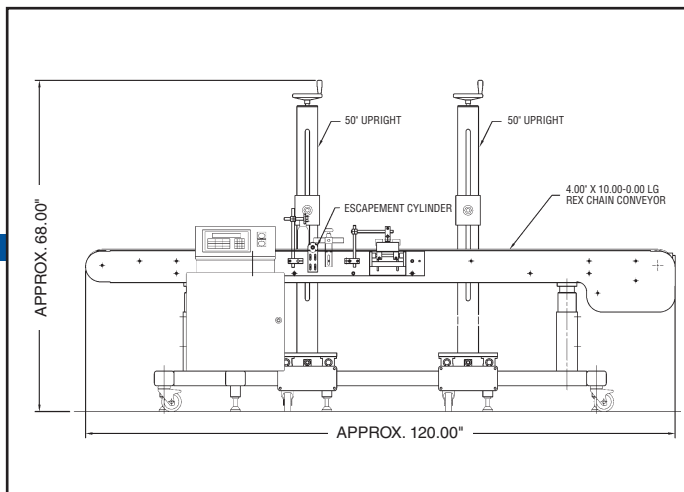
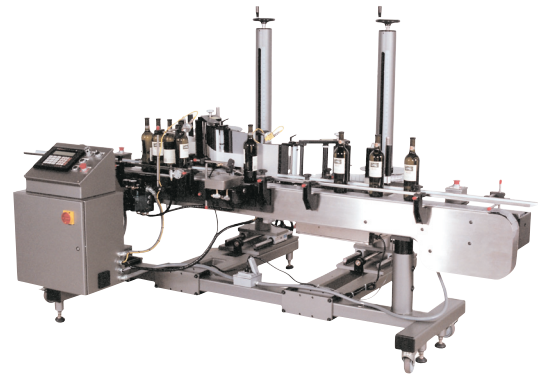

Distributed By:



1318 Quaker Circle
P.O. Box 589
Salem, Ohio 44460
(330) 332-1800

